

DXN MARKETING PLAN

Definition of Terms

PV	: Point Value, for qualification and status.
SV	: Sales Value, for calculation of Bonus and Incentive.
Personal Point Value (PPV) / Personal Sales Value (PSV)	: Total PV/SV generated from all personal cash bills transacted in a month.
Personal Group Point Value (PGPV) / Personal Group Sales Value (PGSV)	: Total PV/SV generated in a month by all downline distributors within personal group (ie. excluding breakaway QSAs) and own PPV/PSV.
Diamond Group Point Value (DGPV) / Diamond Group Sales Value (DGSV)	: Total PV/SV generated in a month by all downline distributors within your diamond group (ie. excluding breakaway QSDs) and own PPV/PSV.
Qualified Start Agent (QSA)	: Any SA who maintains 100 PPV and 300 PGPV in a month.
Qualified Start Diamond (QSD)	: Any Diamond who qualifies for 37% Star Group Bonus.
Travel Seminar Qualifier	: Any SA and above who meets the Yearly Travel Seminar Incentive Points (TSIP) Quota set for the year.

Introduction of Remuneration

1) Retail Profit	-----	15% - 25%
2) Bonus (71%) and Cash Incentive (HUF320.400)		
a) Group Bonus	-----	6% - 21%
b) Star Group Bonus	-----	25% - 37%
c) Development Bonus	-----	15%
d) International Profit Sharing	-----	2%
e) Leadership Bonus	-----	15%
f) Travel Seminar Incentive	-----	2%
g) One Time HP Cash Incentive	-----	HUF41.400
h) One Time Overseas Trip Cash Incentive	-----	HUF279.000

Status

Status	Conditions
Distributor	Membership Fee, Age 18 years + a sponsor
Star Agent (SA)	Achieves accumulated Group Sales of 4,500PV
Star Ruby (SR)	Sponsors 3 First Generation Star Agents (SA)
Star Diamond (SD)	With 6 First Generation Star Agents (SA) + qualifies for 37% Star Group Bonus.
Executive Star Diamond (ESD)	Star Diamond who sponsors 1 Star Diamonds*
Senior Star Diamond (SSD)	Star Diamond who sponsors 2 Star Diamonds*
Executive Senior Star Diamond (ESSD)	Star Diamond who sponsors 3 Star Diamonds*
Double Diamond (DD)	Star Diamond who sponsors 4 Star Diamonds*
Executive Double Diamond (EDD)	Star Diamond who sponsors 5 Star Diamonds*
Triple Diamond (TD)	Star Diamond who sponsors 6 Star Diamonds*
Executive Triple Diamond (ETD)	Star Diamond who sponsors 7 Star Diamonds*
Gold Diamond (GD)	Star Diamond who sponsors 8 Star Diamonds*
Executive Gold Diamond (EGD)	Star Diamond who sponsors 9 Star Diamonds*
Crown Diamond (CD)	Star Diamond who sponsors 10 Star Diamonds*
Executive Crown Diamond (ECD)	Star Diamond who sponsors 11 Star Diamonds*
Senior Crown Diamond (SCD)	Star Diamond who sponsors 12 Star Diamonds*
Executive Senior Crown Diamond (ESCD)	Star Diamond who sponsors 13 Star Diamonds*
Double Crown Diamond (DCD)	Star Diamond who sponsors 14 Star Diamonds*
Executive Double Crown Diamond (EDCD)	Star Diamond who sponsors 15 Star Diamonds*
Triple Crown Diamond (TCD)	Star Diamond who sponsors 16 Star Diamonds*
Executive Triple Crown Diamond (ETCD)	Star Diamond who sponsors 17 Star Diamonds*
Gold Crown Diamond (GCD)	Star Diamond who sponsors 18 Star Diamonds*
Executive Gold Crown Diamond (EGCD)	Star Diamond who sponsors 19 Star Diamonds*
Crown Ambassador (CA)	Star Diamond who sponsors 20 Star Diamonds*

* As per dynamic compression.

1. Retail Profit (15% - 25%)

Direct profit for distributors is when they sell DXN products to non-DXN members. Retail profit is the difference between distributor price and retail price.

2. Group Bonus (6% - 21%)

To be entitled for this Group Bonus, you need to maintain 100 PPV each month.

Accumulated Group PV	Bonus
4.500 and above	21% *
3.250	18%
2.000	15%
1.000	12%
300	9%
100	6%

* If a Star Agent (21%) maintains 100 PPV and 300 PGPV **, he will become a Qualified Star Agent (25%).

3. Star Group Bonus (25% - 37%)

*To be entitled to this Star Group Bonus, you must be a SA and maintain 100 PPV and 300 PGPV ** (QSA)*

No. of SA (1st Generation)	No. of Qualified SA Lines	DGPV	Bonus
6	-	5.000	37%
	4	2.500 #	
5	-	3.000	35%
	4	2.000	
4	4	-	33%
3	3	-	31%
2	2	-	29%
1	1	-	27%
0	0	-	25%

** PGPV is inclusive of personal PV (ie. 100 PPV + 200 PV non-QSA group PV)

For SSD and above, if the number of QSD is more than one, then the DGPV can be borrowed from one of the QSD and the number of QSD will be reduced by one.

4. Development Bonus (15%)

*To be entitled for this Development Bonus, you must be a SA and maintain 100 PPV and 300 PGPV** (QSA).*

Level of Qualified SA	Bonus
1 st Level	5%
2 nd Level	4%
3 rd Level	3%
4 th Level	2%
5 th Level	1%

** PGPV is inclusive of personal PV (ie. 100 PPV + 200 non-QSA group PV).

5. International Profit Sharing (2%)

To be entitled for this International Profit Sharing (IPS) you must be a Qualified Star Diamond (QSD).

IPS Fund = Overall Company's Sales in SV X 2%

Your IPS entitlement

$$= \text{IPS Fund} \times \frac{\text{Your IPS Point for the month}}{\text{Total IPS Point for all Qualified Star Diamond and above}}$$

• Your IPS Point Calculation:

Level of Qualified SD	IPS Point			
Personal			DGSV	X 100%
1 st Level QSD (L1)	+	L1	DGSV	X 50%
2 nd Level QSD (L2)	+	L2	DGSV	X 40%
3 rd Level QSD (L3)	+	L3	DGSV	X 30%
4 th Level QSD (L4)	+	L4	DGSV	X 20%
5 th Level QSD (L5)	+	L5	DGSV	X 10%

6. Leadership Bonus (15%)

To be entitled for this Leadership Bonus, you must be a Qualified Star Diamond (QSD).

No. of Qualified SD Lines	1	2	3	4	5	6	7	8	9	10
1st Level QSD's DGSV	5%	5%	5%	5%	5%	5%	5%	5%	5%	5%
2nd Level and below QSD's DGSV (till 1st level of next qualifier)	-	3%	4.8%	5.8%	6.5%	7.1%	7.6%	8%	8.3%	8.5%
Minimum DGSV needed to Guarantee upline ('000)	126	252	378	504	504	504	504	504	504	504

No. of Qualified SD Lines	11	12	13	14	15	16	17	18	19	20
1st Level QSD's DGSV	5%	5%	5%	5%	5%	5%	5%	5%	5%	5%
2nd Level and below QSD's DGSV (till 1st level of next qualifier)	8.7%	8.9%	9.1%	9.3%	9.5%	9.6%	9.7%	9.8%	9.9%	10%
Minimum DGSV needed to Guarantee upline ('000)	504	504	504	504	504	504	504	504	504	504

7. Travel Seminar Incentive (2%)

This Travel Seminar Incentive (TSI) shall be used by the qualifier for the travel seminar organised by the Company only. It is not exchangeable for cash and also not transferable. A qualifier may claim up to maximum Travel Seminar Fare against his/her TSI for two (2) if married.

$$\text{Travel Seminar Incentive Fund} = \text{Company's Annual Sales in SV} \times 2\%$$

• To be shared as below:

- i) 50% of the Travel Seminar Incentive Fund (TSIF) to be shared amongst all SA and above who met the YEARLY TSIP QUOTA set for the year.
- ii) 50% of the Travel Seminar Incentive Fund (TSIF) to be shared amongst all SD and above who met the YEARLY TSIP QUOTA set for the year.

a) Travel Seminar Incentive for SA Qualifier (TSI_{SA})

$$\text{TSI}_{\text{SA}} = 50\% \times \text{TSIF} \times \frac{\text{Accumulated TSIP* for a SA Qualifier}}{\text{Total Accumulated TSIP for all SA Qualifiers}}$$

* Travel Seminar Incentive Point (TSIP) will be calculated monthly based on the following formula and to be accumulated for a year:

Level of Qualified SA	Monthly Travel Seminar Incentive Point (TSIP)			
Personal			PGSV	X 100%
1 st Level QSA (L1)	+	L1	PGSV	X 50%
2 nd Level QSA (L2)	+	L2	PGSV	X 40%
3 rd Level QSA (L3)	+	L3	PGSV	X 30%
4 th Level QSA (L4)	+	L4	PGSV	X 20%
5 th Level QSA (L5)	+	L5	PGSV	X 10%

b) Travel Seminar Incentive for SD Qualifier (TSI_{SD})

$$\text{TSI}_{\text{SD}} = 50\% \times \text{TSIF} \times \frac{\text{Accumulated TSIP* for a SD Qualifier}}{\text{Total Accumulated TSIP for all SD Qualifiers}}$$

* Travel Seminar Incentive Point (TSIP) will be calculated monthly based on the following formula and to be accumulated for a year:

Level of Qualified SD	Monthly Travel Seminar Incentive Point (TSIP)			
Personal			DGSV	X 100%
1 st Level QSD (L1)	+	L1	DGSV	X 50%
2 nd Level QSD (L2)	+	L2	DGSV	X 40%
3 rd Level QSD (L3)	+	L3	DGSV	X 30%
4 th Level QSD (L4)	+	L4	DGSV	X 20%
5 th Level QSD (L5)	+	L5	DGSV	X 10%

8. Hand Phone Cash Incentive (HUF 41.400) – One Time Only

When you have 3 immediate SA who achieved 6,000 Accumulated GPV, then you will be entitled to receive this One Time Hand Phone Cash Incentive amounting to HUF 41.400.

Only personally sponsored downlines counted.

9. Overseas Trip Cash Incentive HUF 279.000 – One Time Only

When you have 5 immediate downlines who have received their Hand Phone Cash Incentive, then you will be entitled to receive this One Time Overseas Trip Cash Incentive amounting to HUF 279.000.

Only personally sponsored downlines counted.

Explanation On The DXN Marketing Plan Reward

1. Retail Profit (15% - 25%)

Direct profit for distributors is when they sell DXN products to non-DXN members. Retail profit is the difference between distributor price and retail price.

Example:

If you sell one bottle of a DXN Product to a non-member, you will earn the retail profit as below:

One bottle of DXN Product

Distributor Price HUF 6.480

Retail Price HUF 8.100

Therefore,

Retail Price – Distributor Price = Retail Profit

HUF 8.100 – HUF 6.480 = HUF 1.620

YOUR retail profit is HUF 1.620 (25% from the distributor price)

Minimum monthly Personal PV required for bonus entitlement (100PV).

* Example 1

Products	PV	SV
Product A	15	1300
Product B	22	1800
Product C	65	5200
	<u>102</u>	<u>8300</u>

* Assume 1PV = 80SV for all the following Bonuses and Incentives calculations.

2. Group Bonus (6%-21%)

Case 1

If in the first month you have acquired 100 PV and sponsored 3 new distributors with 500PV each:

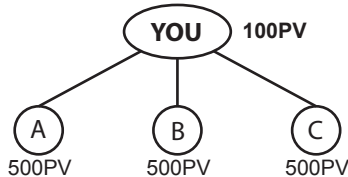

Personal PV (PPV) = 100PV
 Personal SV (PSV) = 8000SV
 Personal Group PV (PGPV) = 1.600PV
 Personal Group SV (PGSV) = 128.000SV

Your Group Bonus = (128.000SV X 12%) - (40.000SV X 9%)
 - (40.000SV X 9%) - (40.000SV X 9%)
 = HUF 15.360 - HUF 3.600 - HUF 3.600 - HUF 3.600
 = HUF 4.560

Therefore:

Your Group Bonus is HUF 4,560 and Group Bonus for A,B and C is HUF 3.600 each.

Case 2

If YOU have acquired 60PV and each one of your downline achieved 500PV;

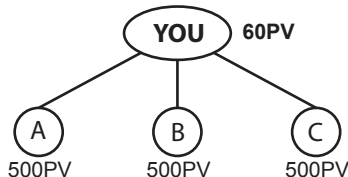

Personal PV (PPV) = 60PV
 Personal Group PV (PGPV) = 1.560PV

You are not qualified to receive any bonus because your Personal PV is less than 100PPV. To qualify for group Bonus, YOU must have a minimum of 100PPV.

3. Star Group Bonus (25% - 37%)

Case 1

If YOU are a Star Ruby (SR) and have sponsored 3 Star Agents (SA) and 2 distributors;

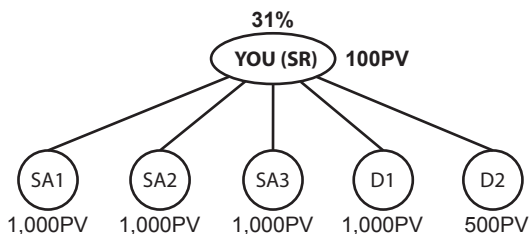

Personal PV (PPV) = 100PV

Personal SV (PSV) = 8.000SV

Personal Group PV (PGPV) = 1.600PV

Personal Group SV (PGSV) = 128.000SV

Your Star Group Bonus = $(368.000SV \times 31\%) - (80.000SV \times 25\%)$
 $- (80.000SV \times 25\%) - (80.000SV \times 25\%)$
 $- (80.000SV \times 12\%) - (40.000SV \times 9\%)$
 = HUF 114.080 - HUF 20.000 - HUF 20.000
 $- HUF 20.000 - HUF 9.600 - HUF 3.600$
 = HUF 40.880

Entonces:

YOUR Star Group Bonus is HUF 40.880.

SA1, SA2 and SA3 will earn HUF 20.000.

Group Bonus for D1 is HUF 9.600 and D2 is HUF 3.600.

Case 2

If YOU are a Star Diamond with 6 SA (1st Generation), 100PPV and 400 PGPV.
 At the same time, YOU have some downlines with the status of Star Ruby (SR) and Star Agent (SA) who have at least 100PV.

The Star Group Bonus entitlement (%) for YOU and your downlines will be as follow:

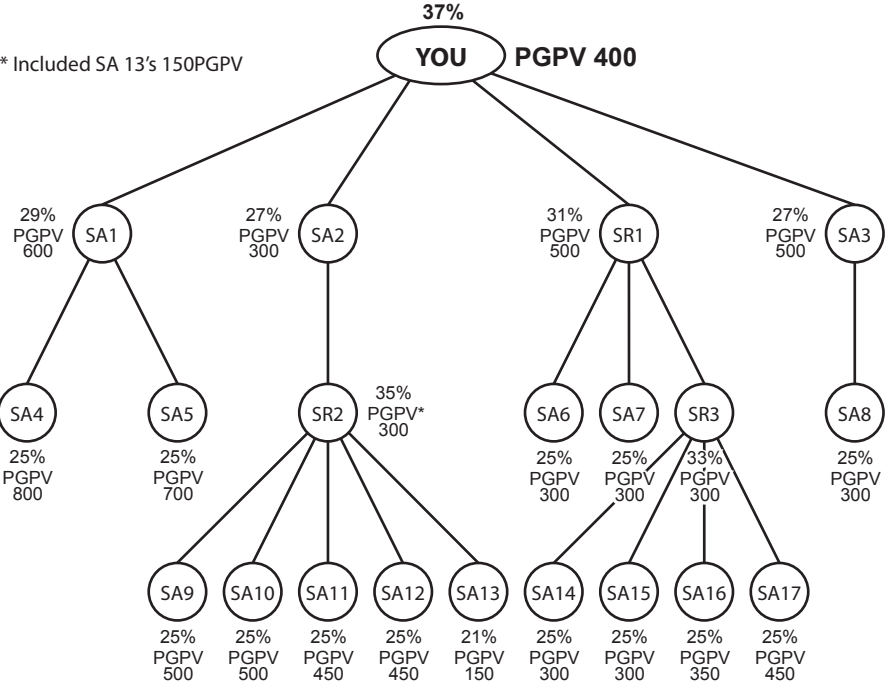

Star Group Bonus (%)

	Status	No of Qualified SA Lines	PPV	PGPV	DGPV	SGB entitlement (%)
YOU	SD	4	100	400	8.600	37%
SA1	SA	2	100	600		29%
SA2	SA	1	100	300		27%
SR1	SR	3	100	500	2.800	31%
SR2	SR	4	100	300	2.200	35%
SR3	SR	4	100	300	1.700	33%
SA4	SA	0	100	800		25%
SA13	SA	0	100	150		21%

Case 3

If YOU are a Star Ruby with 5 SA (1st Generation), 100PPV and 500PGPV.
 At the same time, YOU have downlines with the status of Star Ruby (SR) and Star Agent (SA).
 Some of the SR or SA are inactive (i.e. SA1, SA2, SA5 & SR).

* Included SA4's 200PGPV

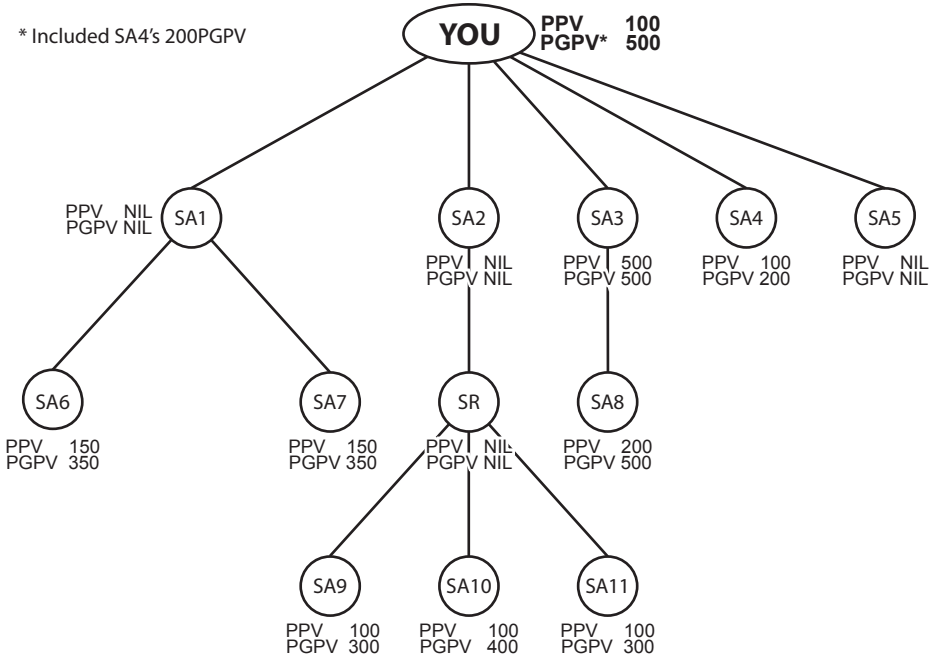

Therefore, YOU are entitled to 35% of Star Group Bonus even you have only 3 qualified SA lines. It is because YOU have 5 SA (1st Generation) and obtained 3.200 DGPV.

4. Development Bonus (15%)

Case 1

For Development Bonus, if YOU are a Star Ruby (SR) and have downlines as below:

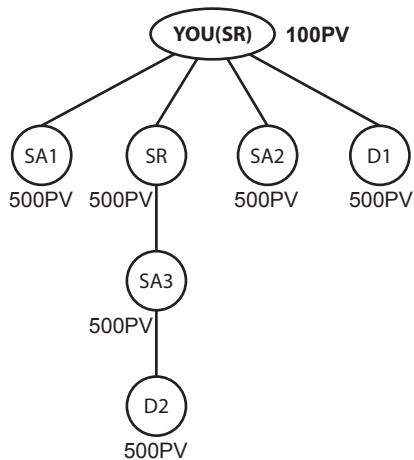

Personal PV (PPV)	=	100PV
Personal SV (PSV)	=	8.000SV
Personal Group PV (PGPV)	=	600PV
Personal Group SV (PGSV)	=	48.000SV

$$\begin{aligned}\text{YOUR Development Bonus} &= (120.000\text{SV} \times 5\%) + (80.000\text{SV} \times 4\%) \\ &= \text{HUF } 6.000 + \text{HUF } 3.200 \\ &= \underline{\underline{\text{HUF } 9.200}}\end{aligned}$$

Therefore:

Your Development Bonus is HUF 9.200.

Case 2

For Development Bonus, if YOU are a Star Ruby (SR) and have downlines are below:

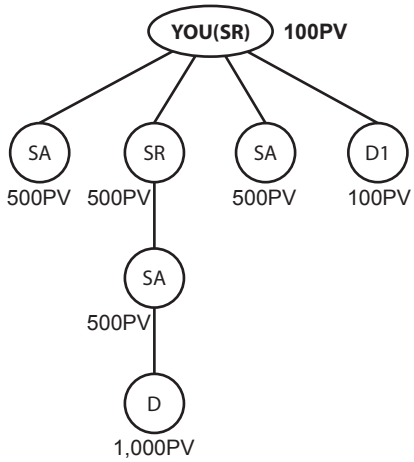

Personal PV (PPV) = 100PV
Personal Group PV (PGPV) = 200PV

YOU are not qualified to earn the development bonus because your Personal Group PV is less than 300PV.

5. International Profit Sharing (2%)

EXAMPLE

YOU are a Senior Star Diamond (SSD) and have downlines of Star Diamond (SD) and above.

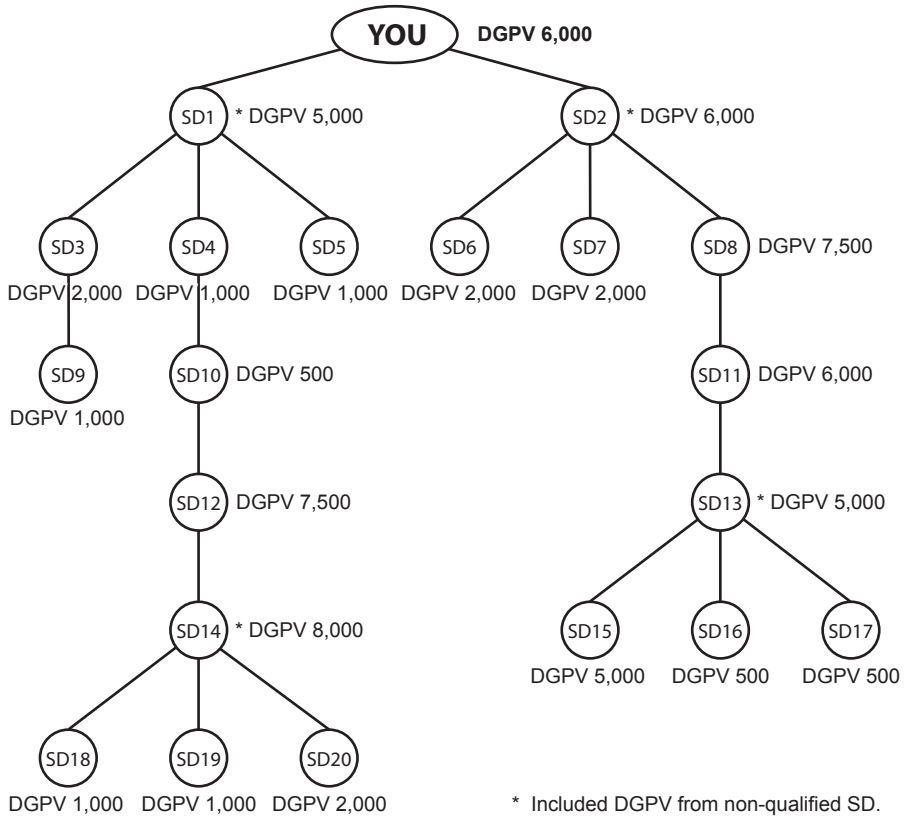

Non-qualified SD: SD: SD3, SD4, SD5, SD6, SD7, SD9, SD10, SD16, SD17, SD18, SD19 & SD20
 Qualified SD : YOU, SD1, SD2, SD8, SD11, SD12, SD13, SD14 & SD15

Assumptions:

- i) 1 PV equals to 80 SV.
- ii) There are 68 Star Diamonds and above in the company and the Total IPS Point is 40.000.000.
- iii) Total company's sales for that particular month is 160.000.000 SV.

IPS Point for YOU:

	DGSV			IPS Points
YOU	480.000	X	100%	= 480.000
1 st Level: SD1 + SD2	880.000	X	50%	= 440.000
2 nd Level: SD12 + SD8	1.200.000	X	40%	= 480.000
3 rd Level: SD14 + SD11	1.120.000	X	30%	= 336.000
4 th Level: SD13	400.000	X	20%	= 80.000
5 th Level: SD15	400.000	X	10%	= 40.000

YOUR Total IPS Point

1.856.000

Therefore:

YOUR International Profit Sharing

$$= 2\% \times 160.000.000\text{SV} \times \frac{1.856.000 \text{ pts}}{40.000.000 \text{ pts}}$$

$$= \underline{\underline{\text{HUF } 148.480}}$$

6. Leadership Bonus (15%)

Case 1

YOU are a Senior Star Diamond (SSD) and have qualified for 37% Star Group Bonus.
 Every Circle (from A1 to C6) represents a SD and above.
 All SDs have qualified for 37% Star Group Bonus.

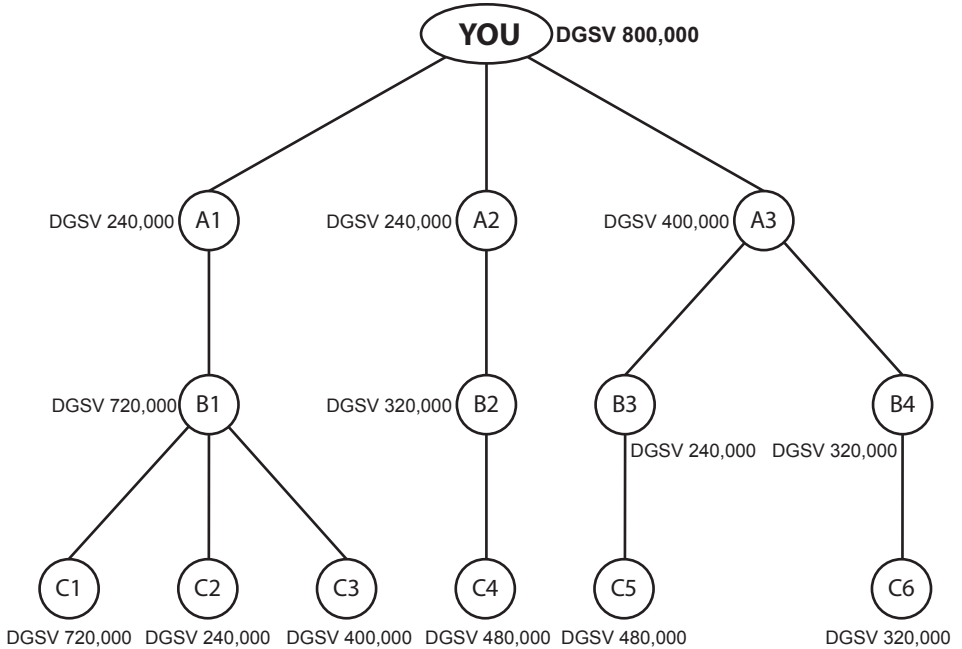

YOUR Leadership Bonus:

1st Level qualified SD:

A1 + A2 + A3

= 880.000SV X 5.0% = HUF 44.000

2nd Level and below qualified SDe:

B1 + C1 + C2 + C3 + B2 + C4 + B3 + B4
 C5 + C6

= 3.440.000SV X 4.8% = HUF 165.120

= 800.000SV X 1.8% = HUF 14.400

YOUR Leadership Bonus

HUF 223.520

Case 2

YOU are a Double Diamond (DD) and have qualified for 37% Star Group Bonus.
 Every Circle (from A1 to C6) represents a SD and above.
 All SDs have qualified for 37% Star Group Bonus with the exception of A1, A2, A5, & B5.

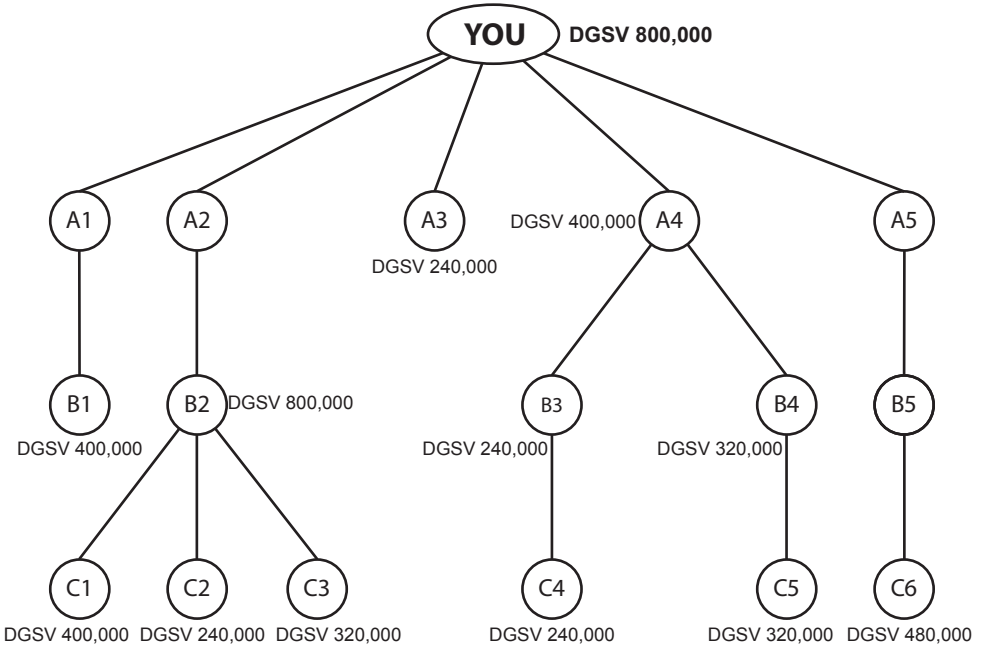

YOUR Leadership Bonus:

1st Level qualified SD:
 B1 + B2 + A3 + A4 + C6 = 2.320.000SV X 5.0% = HUF 116.000

2nd Level and below qualified SD:
 C1 + C2 + C3 + B3 + B4 = 1.520.000SV X 6.5% = HUF 98.800
 C4 + C5 = 560.000SV X 3.5% = HUF 19.600

YOUR Leadership Bonus HUF 234.400

Case 3

YOU are a Double Diamond (DD) and have qualified for 37% Star Group Bonus.
 Every Circle (from A1 to C6) represents a SD and above.
 All SDs have qualified for 37% Star Group Bonus with the exception of A1, A2, A5, & B5.

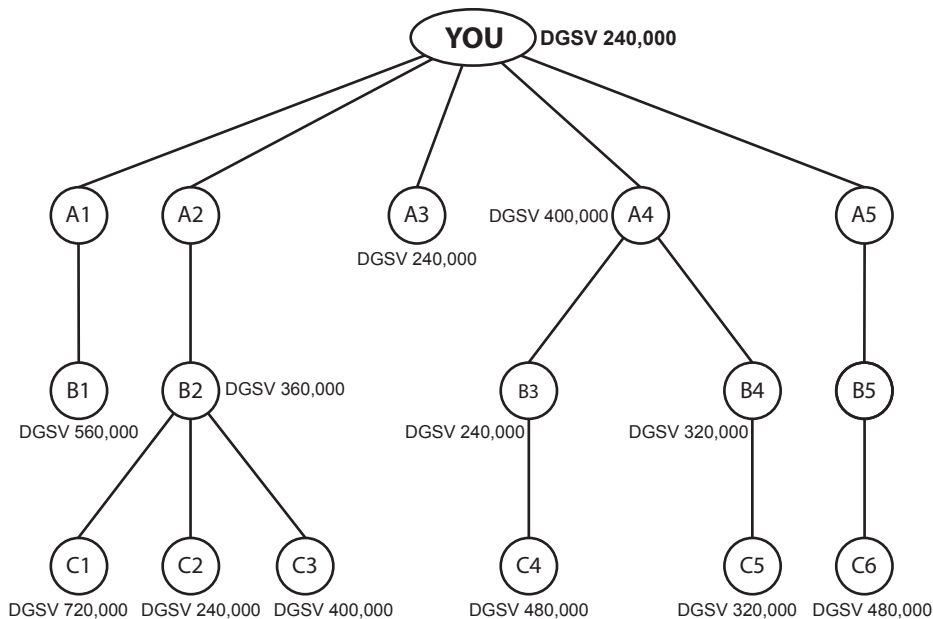

YOUR Leadership Bonus:

1st Level qualified SD:

B1 + B2 + A3 + A4 + C6

2.040.000SV

Add: Guarantee from Downline (B2)

18.000SV

Less: Guarantee Upline (YOU)

(264.000SV)

1.794.000SV X 5.0% = HUF 89.700

2nd Level and below qualified SD:

C1 + C2 + C3 + B3 + B4

1.920.000SV

Less: Guarantee Upline (B2)

(18.000SV)

1.902.000SV X 6.5% = HUF 123.630

C4 + C5

800.000SV X 3.5% = HUF 28.000

YOUR Leadership Bonus

HUF 241.330

* YOU need to guarantee upline 504.000 DGSV.

* B2 need to guarantee upline 378.000 DGSV.

Case 4

YOU are a Crown Ambassador (CA) and have 20 first generation Crown Ambassador (CAs) with 504.000 DGSV each.
 All CAs have 20 Qualified SDs with 504.000 DGSV each.

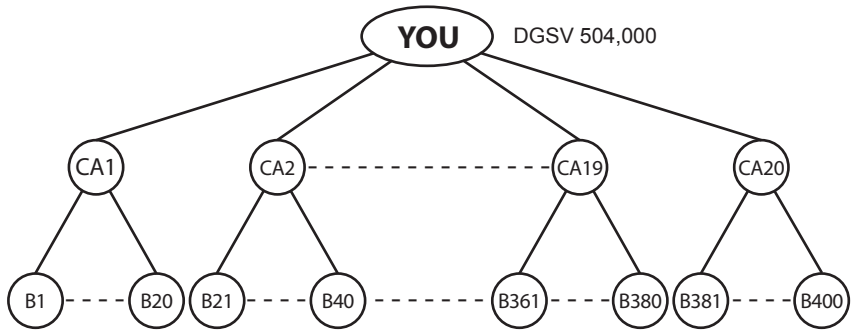

Therefore:

Your Leadership Bonus

1st Level Qualified SD: 504.000 DGSV X 20 X 5%	= HUF 504.000
2nd Level Qualified SD: 504.000 DGSV X 400 X 10%	= HUF 20.160.000
	<u>HUF 20.664.000</u>

7. One Time Hand Phone Cash Incentive

EXAMPLE

After you have sponsored 3 immediate SA who achieved 6,000 Accumulated GPV.

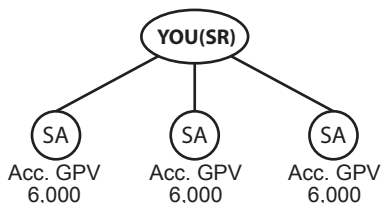

YOU are qualified to receive the One Time Hand Phone Cash Incentive amounting to HUF 41400.

8. One Time Overseas Trip Cash Incentive

EXAMPLE

After you have 5 immediate downlines who have received their Hand Phone Cash Incentive. Then you are qualified for this One Time Overseas Trip Cash Incentive.

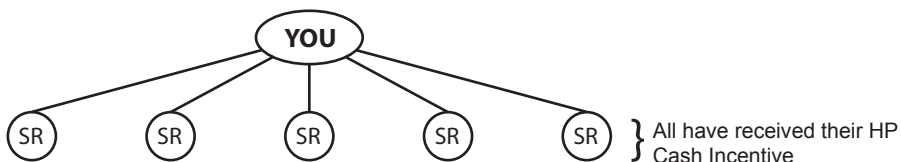

Therefore:

Once YOU have fulfilled the requirements, YOU are qualified for One Time Overseas Trip Cash Incentive amounting to HUF 279,000.

How to become a Star Diamond within 5 months

Assumptions:

- Personal purchase of each distributor is 100PPV per month.
- Each distributor sponsor 3 new distributors in each month.
- 1 PV = 80 SV

1st Month

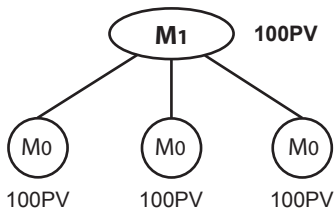

Your status: Distributor - 400PGPV (9%)

Personal PV (PPV)	=	100PV
Personal SV (PSV)	=	8.000SV
Personal Group PV (PGPV)	=	400PV
Personal Group SV (PGSV)	=	32.000SV
Accumulated PGPV	=	400PV

Your Bonus Income		
Group Bonus	= 32.000SV X 9%	= HUF 2.880
Less: Downlines Bonus	= (3 X 8.000SV X 6%)	= (HUF 1.440)
YOUR Bonus Income		<u><u>HUF 1.440</u></u>

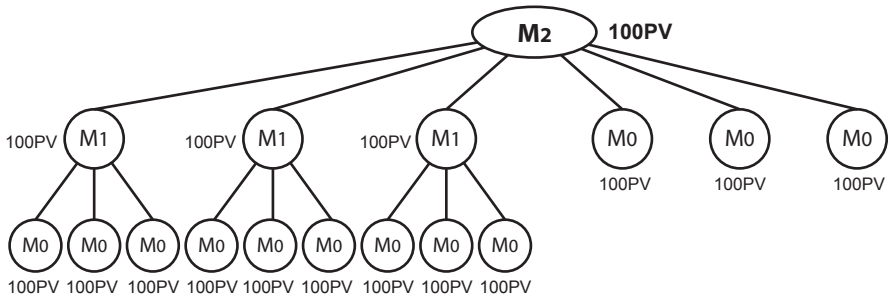

Your status: Distributor - Accumulated 2.000 PGPV (15%)

Personal PV (PPV) = 100PV
 Personal SV (PSV) = 8.000SV
 Personal Group PV (PGPV) = 1.600PV
 Personal Group SV (PGSV) = 128.000SV
 Accumulated PGPV b/f = 400PV
 Accumulated PGPV c/f = 2.000PV

Your Bonus Income		
Group Bonus	= 128.000SV X 15%	= HUF 19.200
Less: Downlines Bonus	= (32.000SV X 9% X 3) + (8.000SV X 6% X 3)	= (HUF 10.080)
YOUR Bonus Income		<u><u>HUF 9.120</u></u>

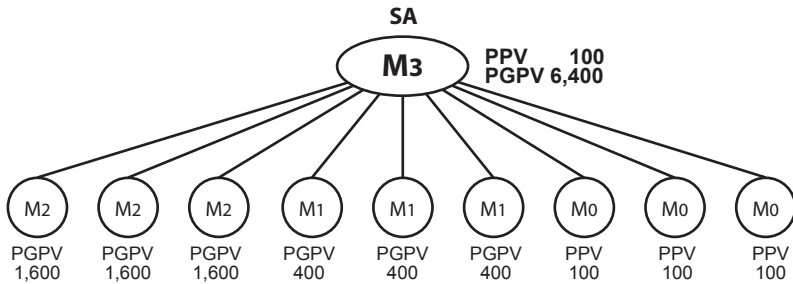

Congratulations! You have reached 4.500 Accumulated PGPV and you are now a Star Agent.

Personal PV (PPV)	=	100PV
Personal SV (PSV)	=	8.000SV
Personal Group PV (PGPV)	=	6.400PV
Personal Group SV (PGSV)	=	512.000SV
Accumulated PGPV b/f	=	2.000PV
Accumulated PGPV c/f	=	8.400PV

Your Bonus Income		
Group Bonus	= 512.000SV X 25%	= HUF 128.000
Less: Downlines Bonus	= (128.000SV X 15% X 3) + (32.000SV X 9% X 3) + (80.000SV X 6% X 3)	= (HUF 67.680)
YOUR Bonus Income		<u><u>HUF 60.320</u></u>

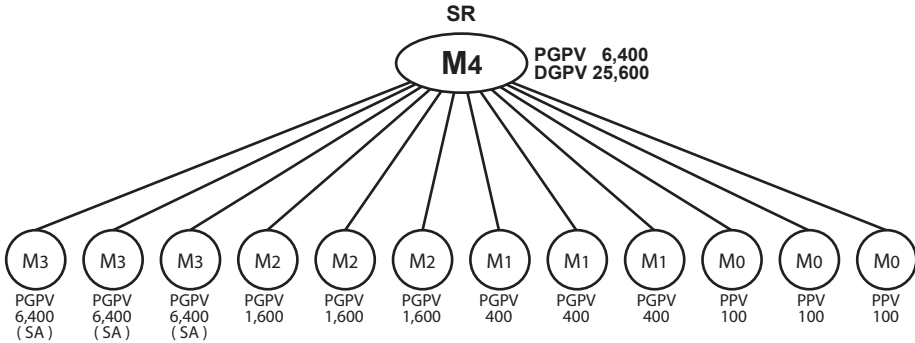

Congratulations! You have successfully promoted 3 direct Star Agent under you, and therefore you are now a Star Ruby.

Personal PV (PPV)	=	100PV
Personal SV (PSV)	=	8.000SV
Personal Group PV (PGPV)	=	6.400PV
personal Group SV (PGSV)	=	512.000SV
Diamond Group PV (DGPV)	=	25.600PV
Diamond Group SV (DGSV)	=	2.048.000SV

Your Bonus Income			
Star Group Bonus	=	2.048.000SV X 31%	= HUF 634.880
Less: Downlines Bonus	=	(512.000SV X 25% X 3) + (128.000SV X 15% X 3) + (32.000SV X 9% X 3) + (8.000SV X 6% X 3)	= (HUF 451.680)
Development Bonus	=	512.000SV X 5% X 3	= HUF 183.200
HP Cash Incentive			HUF 76.800
YOUR Bonus Income			<u>HUF 41.400</u>
			<u>HUF 301.400</u>

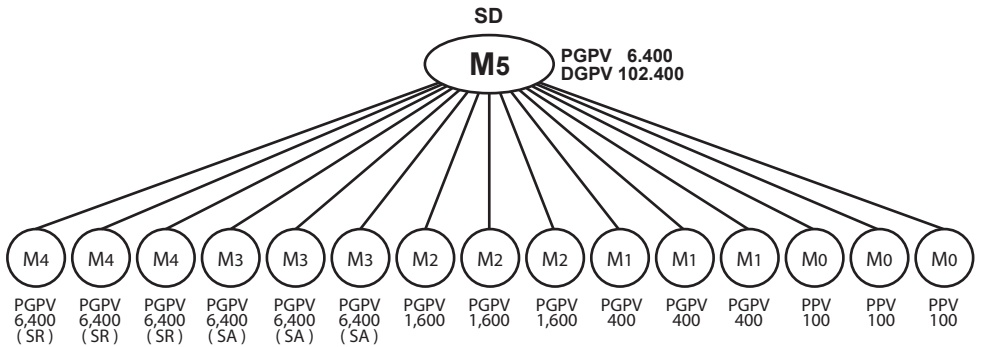

Congratulation! You have successfully promoted 6 SA (1st Generation) and have also met the 5,000DGPV quota. Hence you are now a Star Diamond.

Personal PV (PPV)	=	100PV
Personal SV (PSV)	=	8.000SV
Personal Group PV (PGPV)	=	6.400PV
Personal Group SV (PGSV)	=	512.000SV
Diamond Group PV (DGPV)	=	102.400PV
Diamond Group SV (DGSV)	=	8.192.000SV

Your Bonus Income

(A) Star Group Bonus	=	8.192.000SV X 37%	=	HUF 3.031.040
Less: Downlines Bonus	=	(2.048.000SV X 31% X 3)		
	+	(512.000SV X 25% X 3)		
	+	(128.000SV X 15% X 3)		
	+	(32.000SV X 9% X 3)		
	+	(8.000SV X 6% X 3)	=	<u>(HUF 2.356.320)</u> HUF 674.720

(B) Development Bonus				
1st Level	=	512.000SV X 6 X 5%	=	HUF 153.600
2nd Level	=	512.000SV X 9 X 4%	=	<u>HUF 184.320</u> HUF 337.920

(C) International profit Sharing				
Assumption:				
i) IPS Fund	=	HUF 3.200.000		
ii) Total IPS Point for all Qualifiers	=	5.000.000 pts		
iii) YOUR IPS Point for the month	=	102.400SV X 100%		
	=	<u>102.400 pts</u>		

YOUR International Profit Sharing

=	HUF 3.200.000	X	$\frac{102.400 \text{ pts}}{5.000.000 \text{ pts}}$	=	HUF 65.536
---	---------------	---	---	---	-------------------

YOUR Bonus Income					<u>HUF 1.078.176</u>
-------------------	--	--	--	--	-----------------------------